

# DATA SHEET, SERVICE & OPERATING MANUAL

# B75

## Air Operated Double Diaphragm Pump

### Aluminium, Cast Iron & Stainless Steel Series

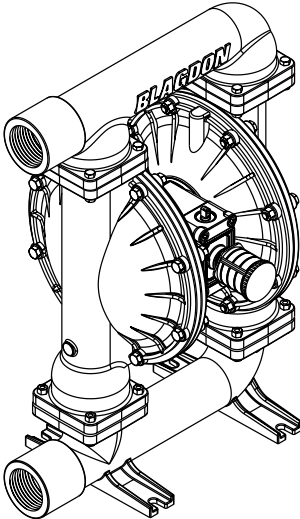

### Table of Contents

- Performance Curve ..... 1
- Dimensions ..... 1
- Engineering Data and Temperature Limitations ..... 2
- Explanation of Pump Nomenclature ..... 2
- Principle of Pump Operation ..... 3
- Installation Guide ..... 3
- Troubleshooting ..... 4
- Warranty ..... 4
- Recycling ..... 4
- Important Safety Information ..... 4
- Material Codes ..... 5
- Composite Repair Parts Drawing ..... 6
- Available Service and Conversion Kits ..... 6
- Composite Repair Parts List ..... 6
- Air Distribution Valve Assembly Drawing and Parts List ..... 7
- Air Distribution Valve Servicing ..... 7
- Pilot Valve Assembly Drawing and Parts List ..... 8
- Pilot Valve Servicing ..... 8
- Diaphragm Service Drawing, with Overlay ..... 9
- Diaphragm Service Drawing, Non-Overlay ..... 9
- Diaphragm Servicing ..... 9
- Overlay Diaphragm Servicing ..... 9
- Check Valve Servicing ..... 10
- Check Valve Drawing ..... 10
- Pumping Hazardous Liquids ..... 10
- Converting Pump for Piping Exhaust Air ..... 10
- Converted Exhaust Illustration ..... 10



# DATA SHEET, SERVICE & OPERATING MANUAL

## B75

### Air Operated Double Diaphragm Pump Aluminium, Cast Iron & Stainless Steel Series

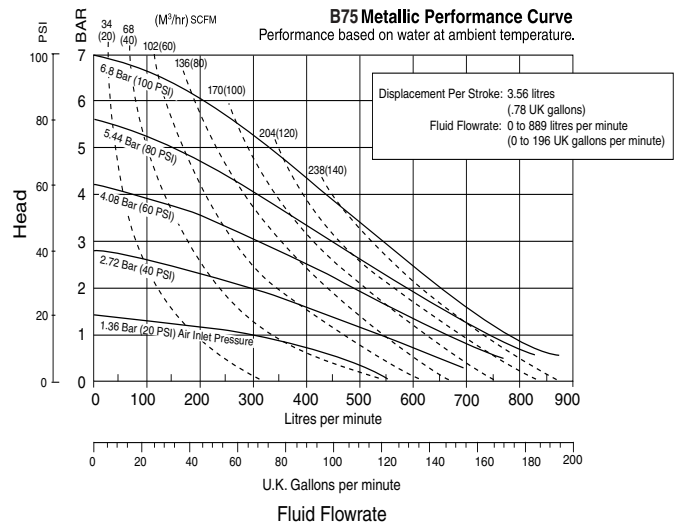
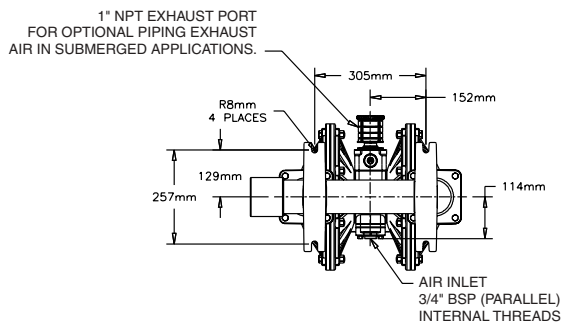
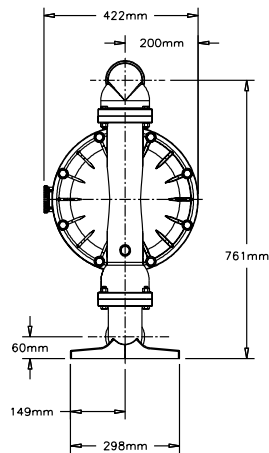
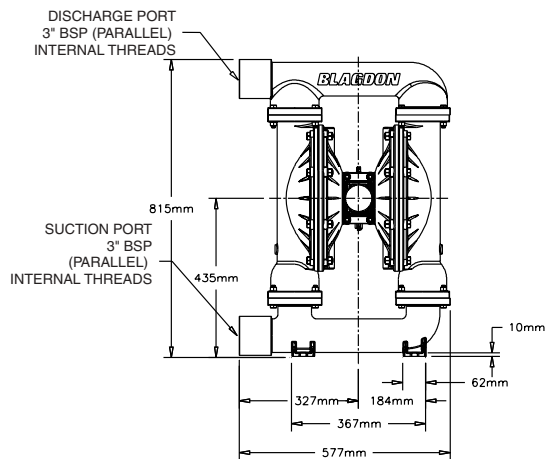
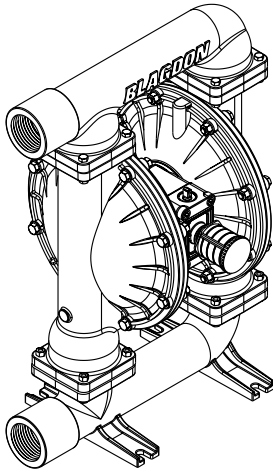

#### IMPORTANT

This pump should be used in accordance with the requirements of the Health and Safety at Work Act 1974.  
All business conducted subject to Blagdon Pump. Terms and Conditions of Sale available on request.

#### **BLAGDON PUMP**

A Unit of IDEX Corporation

[www.blagdonpump.com](http://www.blagdonpump.com)

Lambert Road, Armstrong, Washington,  
Tyne & Wear NE37 1QP ENGLAND  
Tel: (0191) 4177475 Fax: (0191) 4175435  
e-mail: [sales@blagdonpump.com](mailto:sales@blagdonpump.com)

#### DISTRIBUTOR



**PRINCIPLE OF PUMP OPERATION**

This ball type check valve pump is powered by compressed air and is a 1:1 ratio design. The inner side of one diaphragm chamber is alternately pressurised while simultaneously exhausting the other inner chamber. This causes the diaphragms, which are connected by a common rod secured by plates to the centres of the diaphragms, to move in a reciprocating action. (As one diaphragm performs the discharge stroke the other diaphragm is pulled to perform the suction stroke in the opposite chamber.) Air pressure is applied over the entire inner surface of the diaphragm while liquid is discharged from the opposite side of the diaphragm. The diaphragm operates in a balanced condition during the discharge stroke which allows the pump to be operated at discharge heads over 200 feet (61 metres) of water.

For maximum diaphragm life, keep the pump as close to the liquid being pumped as possible. Positive suction head in excess of 10 feet of liquid (3.048 metres) may require a back pressure regulating device to maximize diaphragm life.

Alternate pressurising and exhausting of the diaphragm chamber is performed by an externally mounted, pilot operated, four way spool type air distribution valve. When the spool shifts to one end of the valve body, inlet pressure is applied to one diaphragm chamber and the

other diaphragm chamber exhausts. When the spool shifts to the opposite end of the valve body, the pressure to the chambers is reversed. The air distribution valve spool is moved by an internal pilot valve which alternately pressurises one end of the air distribution valve spool while exhausting the other end. The pilot valve is shifted at each end of the diaphragm stroke when an actuator plunger is contacted by the diaphragm plate. This actuator plunger then pushes the end of the pilot valve spool into position to activate the air distribution valve.

The chambers are connected with manifolds with a suction and discharge check valve for each chamber, maintaining flow in one direction through the pump.

**INSTALLATION AND START-UP**

Locate the pump as close to the product being pumped as possible. Keep the suction line length and number of fittings to a minimum. Do not reduce the suction line diameter.

For installations of rigid piping, short sections of flexible hose should be installed between the pump and the piping. The flexible hose reduces vibration and strain to the pumping system. A Blagdon PD75M pulsation dampener is recommended to further reduce pulsation in flow.

**AIR SUPPLY**

Air supply pressure cannot exceed 125 psi (8.6 bar). Connect the pump air inlet to an air supply of

sufficient capacity and pressure required for desired performance. When the air supply line is solid piping, use a short length of flexible hose not less than 1/2" (13mm) in diameter between the pump and the piping to reduce strain to the piping. The weight of the air supply line, regulators and filters must be supported by some means other than the air inlet cap. Failure to provide support for the piping may result in damage to the pump. A pressure regulating valve should be installed to insure air supply pressure does not exceed recommended limits.

**AIR VALVE LUBRICATION**

The air distribution valve and the pilot valve are designed to operate WITHOUT lubrication. This is the preferred mode of operation. There may be instances of personal preference or poor quality air supplies when lubrication of the compressed air supply is required. The pump air system will operate with properly lubricated compressed air supply. Proper lubrication requires the use of an air line lubricator (available from Blagdon) set to deliver one drop of SAE 10 non-detergent oil for every 20 SCFM (9.4 liters/sec.) of air the pump consumes at the point of operation. Consult the pump's published Performance Curve to determine this.

**AIR LINE MOISTURE**

Water in the compressed air supply can create problems such as icing or freezing of the exhaust air, causing the

pump to cycle erratically or stop operating. Water in the air supply can be reduced by using a point-of-use air dryer to supplement the user's air drying equipment. This device removes water from the compressed air supply and alleviates the icing or freezing problems.

**AIR INLET AND PRIMING**

To start the pump, open the air valve approximately 1/2 to 3/4 turn. After the pump primes, the air valve can be opened to increase air flow as desired. If opening the valve increases cycling rate, but does not increase the rate of flow, cavitation has occurred. The valve should be closed slightly to obtain the most efficient air flow to pump flow ratio.

**BETWEEN USES**

When the pump is used for materials that tend to settle out or solidify when not in motion, the pump should be flushed after each use to prevent damage. (Product remaining in the pump between uses could dry out or settle out. This could cause problems with the diaphragms and check valves at restart.) In freezing temperatures the pump must be completely drained between uses in all cases.

**INSTALLATION GUIDE**  
Top Discharge Ball Unit

Available from  
Blagdon Pump

- ① PD75M Pulsation Dampener
- ② 020-052-000 Filter/Regulator
- ③ 020-052-001 Lubricator
- ④ 020-048-008 Air Dryer

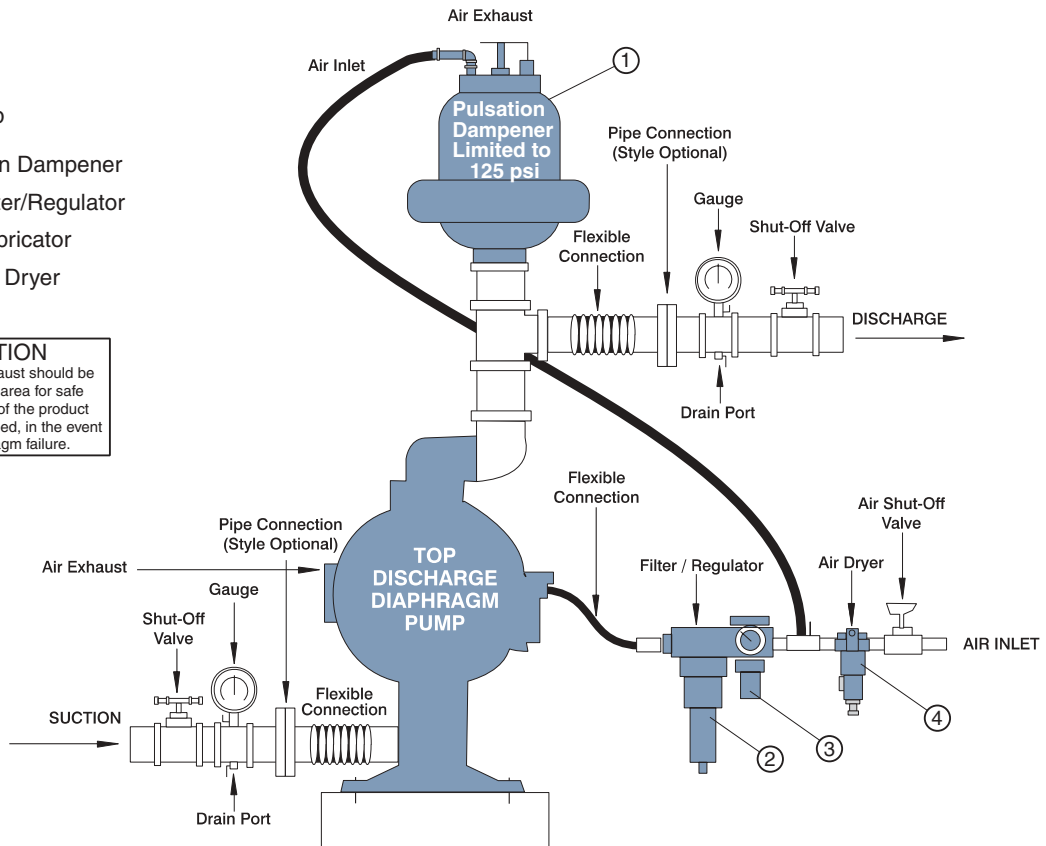
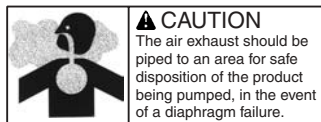

## TROUBLESHOOTING

### Possible Symptoms:

- Pump will not cycle.
- Pump cycles, but produces no flow.
- Pump cycles, but flow rate is unsatisfactory.
- Pump cycle seems unbalanced.
- Pump cycle seems to produce excessive vibration.

**What to Check:** Excessive suction lift in system.

**Corrective Action:** For lifts exceeding 20 feet (6 meters), filling the pumping chambers with liquid will prime the pump in most cases.

**What to Check:** Excessive flooded suction in system.

**Corrective Action:** For flooded conditions exceeding 10 feet (3 meters) of liquid, install a back pressure device.

**What to Check:** System head exceeds air supply pressure.

**Corrective Action:** Increase the inlet air pressure to the pump. Most diaphragm pumps are designed for 1:1 pressure ratio at zero flow.

**What to Check:** Air supply pressure or volume exceeds system head.

**Corrective Action:** Decrease inlet air pressure and volume to the pump as calculated on the published PERFORMANCE CURVE. Pump is cavitating the fluid by fast cycling.

**What to Check:** Undersized suction line.

**Corrective Action:** Meet or exceed pump connection recommendations shown on the DIMENSIONAL DRAWING.

**What to Check:** Restricted or undersized air line.

**Corrective Action:** Install a larger air line and connection. Refer to air inlet recommendations shown in your pump's SERVICE MANUAL.

**What to Check:** Check ESADS, the Externally Serviceable Air Distribution System of the pump.

**Corrective Action:** Disassemble and inspect the main air distribution valve, pilot valve and pilot valve actuators. Refer to the parts drawing and air valve section of the SERVICE MANUAL. Check for clogged discharge or closed valve before reassembly.

**What to Check:** Rigid pipe connections to pump.

**Corrective Action:** Install flexible connectors and a Blagdon PD50M surge suppressor.

**What to Check:** Blocked air exhaust muffler.

**Corrective Action:** Remove muffler screen, clean or de-ice and reinstall. Refer to the Air Exhaust section of your pump SERVICE MANUAL.

**What to Check:** Pumped fluid in air exhaust muffler.

**Corrective Action:** Disassemble pump chambers. Inspect for diaphragm rupture or loose diaphragm plate assembly. Refer

to the Diaphragm Replacement section of your pump SERVICE MANUAL.

**What to Check:** Suction side air leakage or air in product.

**Corrective Action:** Visually inspect all suction side gaskets and pipe connections.

**What to Check:** Obstructed check valve.

**Corrective Action:** Disassemble the wet end of the pump and manually dislodge obstruction in the check valve pocket. Refer to the Check Valve section of the pump SERVICE MANUAL for disassembly instructions.

**What to Check:** Worn or misaligned check valve or check valve seat.

**Corrective Action:** Inspect check valves and seats for wear and proper seating. Replace if necessary. Refer to Check Valve section of the pump SERVICE MANUAL for disassembly instructions.

**What to Check:** Blocked suction line.

**Corrective Action:** Remove or flush obstruction. Check and clear all suction screens and strainers.

**What to Check:** Blocked discharge line.

**Corrective Action:** Check for obstruction or closed discharge line valves.

**What to Check:** Blocked pumping chamber.

**Corrective Action:** Disassemble and inspect the wetted chambers of the pump. Remove or flush any obstructions.

Refer to the pump SERVICE MANUAL for disassembly instructions.

**What to Check:** Entrained air or vapor lock in one or both pumping chambers.

**Corrective Action:** Purge chambers through tapped chamber vent plugs. PURGING THE CHAMBERS OF AIR CAN BE DANGEROUS! Contact the Blagdon Technical Services Department before performing this procedure. Any model with top-ported discharge will reduce or eliminate problems with entrained air.

If your pump continues to perform below your expectations, contact your local Blagdon Distributor or factory Technical Services Group for a service evaluation.



### WARNING!

*Read these safety warnings and instructions in this manual COMPLETELY, before installation and start-up of the pump. It is the responsibility of the purchaser to retain this manual for reference. Failure to comply with the recommendations stated in this manual will damage the pump, and void factory warranty.*



### WARNING!

*Before doing any maintenance on the pump, be certain all pressure is completely vented from the pump, suction, discharge, piping, and all other openings and connections. Be certain the air supply is locked out or made non-operational, so that it cannot be started while work is being done on the pump. Be certain that approved eye protection and protective clothing are worn all times in the vicinity of the pump. Failure to follow these recommendations may result in serious injury or death.*



### CAUTION!

*Before pump operation, inspect all gasketed fasteners for looseness caused by gasket creep. Re-torque loose fasteners to prevent leakage. Follow recommended torques stated in this manual.*



### WARNING!

*Before maintenance or repair, shut off the compressed air line, bleed the pressure, and disconnect the air line from the pump. The discharge line may be pressurised and must be bled of its pressure.*



### WARNING!

*Take action to prevent static sparking. Fire or explosion can result, especially when handling flammable liquids. The pump, piping, valves, containers or other miscellaneous equipment must be grounded.*



### IMPORTANT!

*This pump is pressurised internally with air pressure during operation. Always make certain that all bolting is in good condition and that all of the correct bolting is reinstalled during assembly.*



### WARNING!

*Airborne particles and loud noise hazards. Wear ear and eye protection.*



### WARNING!

*When used for toxic or aggressive fluids, the pump should always be flushed clean prior to disassembly.*



### WARNING!

*In the event of diaphragm rupture, pumped material may enter the air end of the pump, and be discharged into the atmosphere. If pumping a product which is hazardous or toxic, the air exhaust must be piped to an appropriate area for safe disposition.*

## RECYCLING

Many components of Blagdon Metallic AODD pumps are made of recyclable materials (see chart on page 9 for material specifications). We encourage pump users to recycle worn out parts and pumps whenever possible, after any hazardous pumped fluids are thoroughly flushed.

# MATERIAL CODES

## The Last 3 Digits of Part Number

000 ..... Assembly, sub-assembly;  
and some purchased items

010 ..... Cast Iron  
012 ..... Powered Metal  
015 ..... Ductile Iron  
020 ..... Ferritic Malleable Iron  
025 ..... Music Wire  
080 ..... Carbon Steel, AISI B-1112  
100 ..... Alloy 20  
110 ..... Alloy Type 316 Stainless Steel  
111 ..... Alloy Type 316 Stainless Steel  
(Electro Polished)  
112 ..... Alloy "C" (Hastelloy equivalent)  
113 ..... Alloy Type 316 Stainless Steel  
(Hand Polished)  
114 ..... 303 Stainless Steel  
115 ..... 302/304 Stainless Steel  
117 ..... 440-C Stainless Steel (Martensitic)  
120 ..... 416 Stainless Steel  
(Wrought Martensitic)  
123 ..... 410 Stainless Steel (Wrought Martensitic)  
148 ..... Hardcoat Anodized Aluminium  
149 ..... 2024-T4 Aluminium  
150 ..... 6061-T6 Aluminium  
151 ..... 6063-T6 Aluminium  
152 ..... 2024-T4 Aluminium (2023-T351)  
154 ..... Almag 35 Aluminium  
155 ..... 356-T6 Aluminium  
156 ..... 356-T6 Aluminium  
157 ..... Die Cast Aluminium Alloy #380  
158 ..... Aluminium Alloy SR-319  
159 ..... Anodized Aluminium  
162 ..... Brass, Yellow, Screw Machine Stock  
165 ..... Cast Bronze, 85-5-5-5  
166 ..... Bronze, SAE 660  
170 ..... Bronze, Bearing Type,  
Oil Impregnated  
175 ..... Die Cast Zinc  
180 ..... Copper Alloy  
305 ..... Carbon Steel, Gray Epoxy Coated  
306 ..... Carbon Steel, Black PTFE Coated  
307 ..... Aluminium, Gray Epoxy Coated  
308 ..... Stainless Steel, Black PTFE Coated  
309 ..... Aluminium, Black PTFE Coated  
310 ..... Kynar Coated  
330 ..... Zinc Plated Steel  
331 ..... Chrome Plated Steel

332 ..... Aluminium, Electroless Nickel Plated  
333 ..... Carbon Steel, Electroless  
Nickel Plated  
335 ..... Galvanized Steel  
336 ..... Zinc Plated Yellow Brass  
337 ..... Silver Plated Steel  
340 ..... Nickel Plated  
342 ..... Filled Nylon  
353 ..... Geolast; Color: Black  
354 ..... Injection Molded #203-40 Santoprene- Duro 40D +/-5;  
Color: RED  
355 ..... Thermal Plastic  
356 ..... Hytrel  
357 ..... Injection Molded Polyurethane  
358 ..... (Urethane Rubber) (Compression Mold)  
359 ..... Urethane Rubber  
360 ..... Buna-N Rubber. Color coded: RED  
361 ..... Buna-N  
363 ..... Viton (Fluorel). Color coded: YELLOW  
364 ..... E.P.D.M. Rubber. Color coded: BLUE  
365 ..... Neoprene Rubber.  
Color coded: GREEN  
366 ..... Food Grade Nitrile  
368 ..... Food Grade EPDM  
370 ..... Butyl Rubber. Color coded: BROWN  
371 ..... Philthane (Tuftane)  
374 ..... Carboxylated Nitrile  
375 ..... Fluorinated Nitrile  
378 ..... High Density Polypropylene  
405 ..... Cellulose Fibre  
408 ..... Cork and Neoprene  
425 ..... Compressed Fibre  
426 ..... Blue Gard  
440 ..... Vegetable Fibre  
465 ..... Fibre  
500 ..... Delrin 500  
501 ..... Delrin 570  
502 ..... Conductive Acetal, ESD-800  
503 ..... Conductive Acetal, Glass-Filled  
505 ..... Acrylic Resin Plastic  
506 ..... Delrin 150  
520 ..... Injection Molded PVDF Natural color  
540 ..... Nylon  
541 ..... Nylon  
542 ..... Nylon  
544 ..... Nylon Injection Molded  
550 ..... Polyethylene  
551 ..... Glass Filled Polypropylene

552 ..... Unfilled Polypropylene  
553 ..... Unfilled Polypropylene  
555 ..... Polyvinyl Chloride  
556 ..... Black Vinyl  
570 ..... Rulon II  
580 ..... Rytan  
590 ..... Valox  
591 ..... Nylatron G-S  
592 ..... Nylatron NSB  
600 ..... PTFE (virgin material)  
Tetrafluorocarbon (TFE)  
601 ..... PTFE (Bronze and moly filled)  
602 ..... Filled PTFE  
603 ..... Blue Gylon  
604 ..... PTFE  
607 ..... Envelon  
606 ..... PTFE  
610 ..... PTFE Encapsulated Silicon  
611 ..... PTFE Encapsulated Viton  
632 ..... Neoprene/Hytrel  
633 ..... Viton/PTFE  
634 ..... EPDM/PTFE  
635 ..... Neoprene/PTFE  
637 ..... PTFE, Viton/PTFE  
638 ..... PTFE, Hytrel/PTFE  
639 ..... Buna-N/TFE  
643 ..... Santoprene®/EPDM  
644 ..... Santoprene®/PTFE  
656 ..... Santoprene Diaphragm and  
Check Balls/EPDM Seats

Delrin, Viton and Hytrel are  
registered tradenames of E.I. DuPont.

Gylon is a registered tradename of Garlock, Inc.

Nylatron is a registered tradename of  
Polymer Corp.

Santoprene is a registered tradename of Monsanto Corp.

Rulon II is a registered tradename of  
Dixon Industries Corp.

Hastelloy-C is a registered tradename of Cabot Corp.

Rytan is a registered tradename of  
Phillips Chemical Co.

Valox is a registered tradename of  
General Electric Co.

# Composite Repair Parts Drawing

## AVAILABLE SERVICE AND CONVERSION KITS

- B476-169-000 AIR END KIT**  
Seals, O-ring, Gaskets, Retaining Rings, Air Valve Sleeve and Spool Set, and Pilot Valve Assembly
- B476-185-360 WET END KIT**  
Buna Diaphragms, Balls, and Seats.
- B476-185-656 WET END KIT**  
Santoprene Diaphragms and Balls, EPDM Seats.
- B476-185-364 WET END KIT**  
EPDM Diaphragms, Balls and Seats.
- B476-185-365 WET END KIT**  
Neoprene Diaphragms, Balls, and Seats.
- B476-185-633 WET END KIT**  
Viton Diaphragms, PTFE Balls, and Seats.
- B476-185-635 WET END KIT**  
Neoprene Diaphragms, PTFE Overlay, Balls, and Seats.

## HARDWARE KITS

- B475-197-330** Zinc Plated Capscrews, Washers, and Hex Nuts

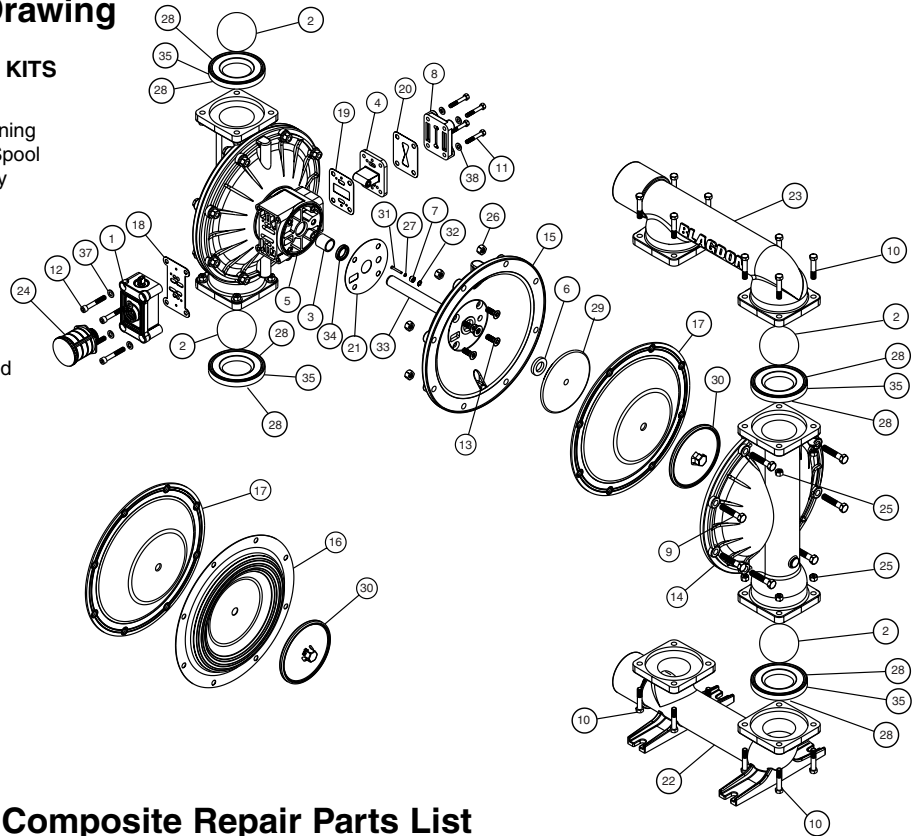

## Composite Repair Parts List

ITEM	PART NO.	DESCRIPTION	QTY	ITEM	PART NO.	DESCRIPTION	QTY
1	B031-141-000	Air Valve Assembly	1	21	B360-105-360	Gasket, Inner Chamber	2
2	B050-014-354	Ball, Check	4	22	B518-155-010E	Manifold, Suction 3" BSP (Parallel)	1
	B050-014-360	Ball, Check	4		B518-155-110E	Manifold, Suction 3" BSP (Parallel)	1
	B050-014-360W	Ball, Check(Weighted)	4		B518-155-156E	Manifold, Suction 3" BSP (Parallel)	1
	B050-014-363	Ball, Check	4	23	B518-156-010E	Manifold, Discharge 3" BSP (Parallel)	1
	B050-014-363W	Ball, Check(Weighted)	4		B518-156-110E	Manifold, Discharge 3" BSP (Parallel)	1
	B050-014-364	Ball, Check	4		B518-156-156E	Manifold, Discharge 3" BSP (Parallel)	1
	B050-014-364W	Ball, Check(Weighted)	4	24	B530-010-000	Silencer	1
	B050-014-365	Ball, Check	4	25	B545-005-330	Nut, Hex 7/16-14	16
	B050-014-365W	Ball, Check(Weighted)	4	26	B545-007-330	Nut, Hex 1/2-13	16
	B050-014-600	Ball, Check	4	27	B560-001-360	O-Ring	2
3	B070-006-170	Bushing	2	28	B560-105-360	Seal (O-Ring) (see item 35)	8
4	B095-096-000	Pilot Valve Assembly	1		B560-105-363	Seal (O-Ring) (see item 35)	8
5	B114-024-157	Intermediate, Bracket	1		B560-105-364	Seal (O-Ring) (see item 35)	8
	B114-024-010	Intermediate, Bracket	1		B560-105-365	Seal (O-Ring) (see item 35)	8
6	B132-035-360	Bumper, Diaphragm	2		B720-055-600	Seal (see item 35)	8
7	B135-034-506	Bushing, Plunger	2	29	B612-192-157	Plate, Inner Diaphragm	2
8	B165-113-157E	Cap, Air Inlet Assembly	1		B612-192-010	Plate, Inner Diaphragm	2
	B165-113-010E	Cap, Air Inlet Assembly	1	30	B612-194-010	Plate, Outer Diaphragm	2
9	B170-055-330	Capscrew, Hex Hd 1/2-13 x 2.50	16		B612-194-110	Plate, Outer Diaphragm	2
10	B170-060-330	Capscrew, Hex Hd 7/6-14 x 2.00	16		B612-194-156	Plate, Outer Diaphragm	2
11	B170-085-330	Capscrew, Hex Hd 5/16-18 x 2.00	4	31	B620-020-115	Plunger, Actuator	2
12	B171-053-330	Capscrew, Soc Hd 3/8-16 x 2.50	4	32	B675-042-115	Ring, Retaining	2
13	B171-059-330	Capscrew, Soc Hd 7/16-14 x 1.25	8	33	B685-040-120	Rod, Diaphragm	1
14	B196-164-156	Chamber, Outer	2	34	B720-004-360	Seal, Diaphragm Rod	2
	B196-164-010	Chamber, Outer	2	35	B722-090-360	Seat, Check Ball	4
15	B196-165-156	Chamber, Inner	2		B722-090-363	Seat, Check Ball	4
	B196-165-010	Chamber, Inner	2		B722-090-364	Seat, Check Ball	4
16	B286-101-360	Diaphragm	2		B722-090-365	Seat, Check Ball	4
	B286-101-363	Diaphragm	2		B722-090-600	Seat, Check Ball	4
	B286-101-364	Diaphragm	2		B722-090-080	Seat, Check Ball (seals required see item 28)	4
	B286-101-365	Diaphragm	2		B722-090-110	Seat, Check Ball (seals required see item 28)	4
17	B286-101-604	Diaphragm, Overlay	2		B722-090-150	Seat, Check Ball (seals required see item 28)	4
18	B360-093-360	Gasket, Air Valve	1	37	B901-038-330	5/16 Flat Washer	4
19	B360-103-360	Gasket, Pilot Valve	1	38	B901-048-330	3/8 Flat Washer	4
20	B360-104-360	Gasket, Air Inlet	1				



# Air Valve Assembly Drawing, Parts List

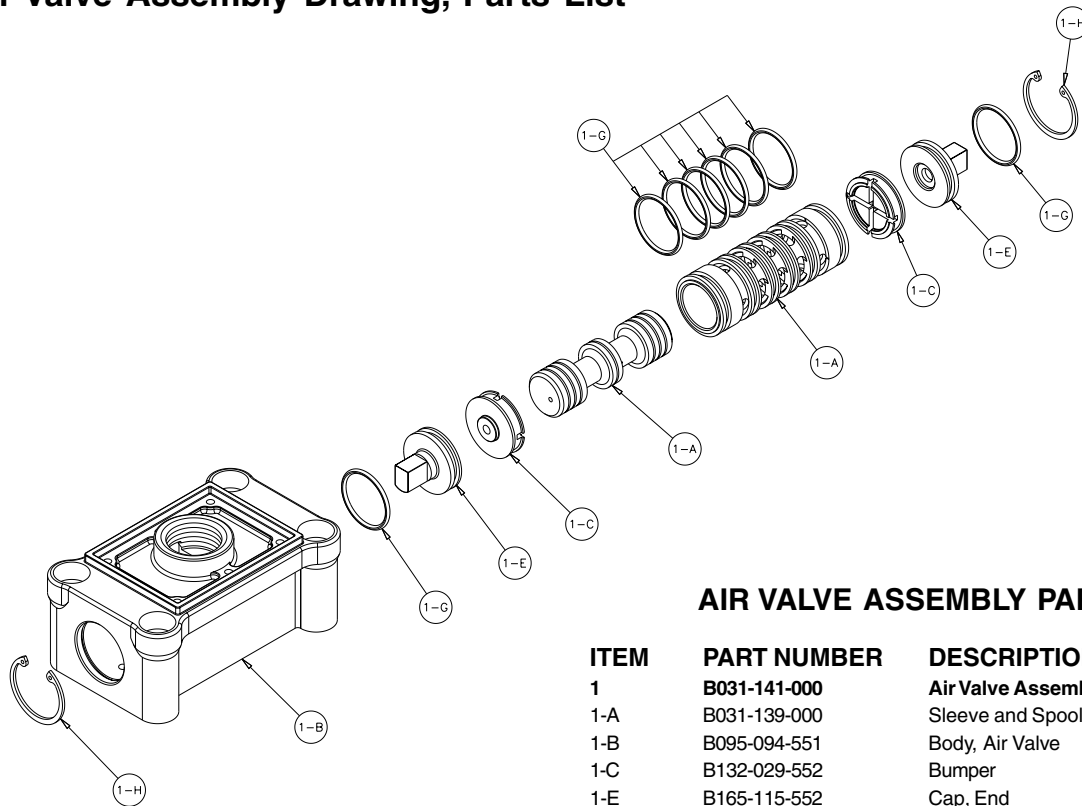

## AIR VALVE ASSEMBLY PARTS LIST

ITEM	PART NUMBER	DESCRIPTION	QTY
1	B031-141-000	Air Valve Assembly	1
1-A	B031-139-000	Sleeve and Spool Set	1
1-B	B095-094-551	Body, Air Valve	1
1-C	B132-029-552	Bumper	2
1-E	B165-115-552	Cap, End	2
1-G	B560-020-360	O-Ring	8
1-H	B675-044-115	Ring, Retaining	2

### AIR DISTRIBUTION VALVE SERVICING

To service the air valve first shut off the compressed air, bleed pressure from the pump, and disconnect the air supply line from the pump.

#### STEP #1: See COMPOSITE REPAIR PARTS DRAWING.

Using a 5/16" Allen wrench, remove the four hex socket capscrews (item 12) and four flat washers (item 37). Remove the air valve assembly from the pump.

Remove and inspect gasket (item 18) for cracks or damage. Replace gasket if needed.

#### STEP #2: Disassembly of the air valve.

To access the internal air valve components first remove the two retaining rings (item 1-H) from each end of the air valve assembly using clip ring pliers.

Next remove the two end caps (item 1-E). Inspect the o-rings (item 1-G) for cuts or wear. Replace the o-rings if necessary.

Remove the two bumpers (items 1-C). Inspect for cuts, wear, or abrasion. Replace bumpers if necessary.

Remove the spool (part of item 1-A) from the sleeve. Be careful not to scratch or damage the outer diameter of the spool. Wipe spool with a soft cloth and inspect for scratches or wear.

Inspect the inner diameter of the sleeve (part of item 1-A) for dirt, scratches, or other contaminants. Remove the sleeve if needed and replace with a new sleeve and spool set (item 1-A).

#### STEP #3: Reassembly of the air valve.

Install one bumper (item 1-C) one end cap (item 1-E) with an o-ring (item 1-G) into one end of the air valve body (item 1-B). Install one retaining ring (item 1-H) into the groove on the same end.

Remove the new sleeve and spool set (item 1-A) from the plastic bag. Carefully remove the spool from the sleeve. Install the six o-rings (item 1-G) into the six grooves on the sleeve. Apply a light coating of grease to the o-rings before installing the sleeve into the valve body (item 1-B), align the slots in the sleeve with the slots in the valve body. Insert the spool into the sleeve. Be careful not to scratch or

damage the spool during installation. Push the spool in until it touches the bumper on the opposite end.

Install the remaining bumper, end cap with o-ring, and retaining ring.

Fasten the air valve assembly (item 1) and gasket (item 18) to the pump.

Connect the compressed air line to the pump. The pump is now ready for operation.



### IMPORTANT!

*Read these instructions completely, before installation and start-up. It is the responsibility of the purchaser to retain this manual for reference. Failure to comply with the recommendations stated in this manual will damage the pump, and void factory warranty.*

# Pilot Valve Assembly Drawing

# PILOT VALVE ASSEMBLY PARTS LIST

ITEM	PART NUMBER	DESCRIPTION	QTY
4	B095-096-000	Pilot Valve Assembly	1
4-A	B095-095-551	Body, Pilot Valve	1
4-B	B135-037-506	Bushing	2
4-C	B675-057-115	Ring, Retaining	2
4-D	B770-065-175	Spacer	5
4-E	B775-041-506	Spool, Pilot	1
4-F	B917-003-374	Wiper	6

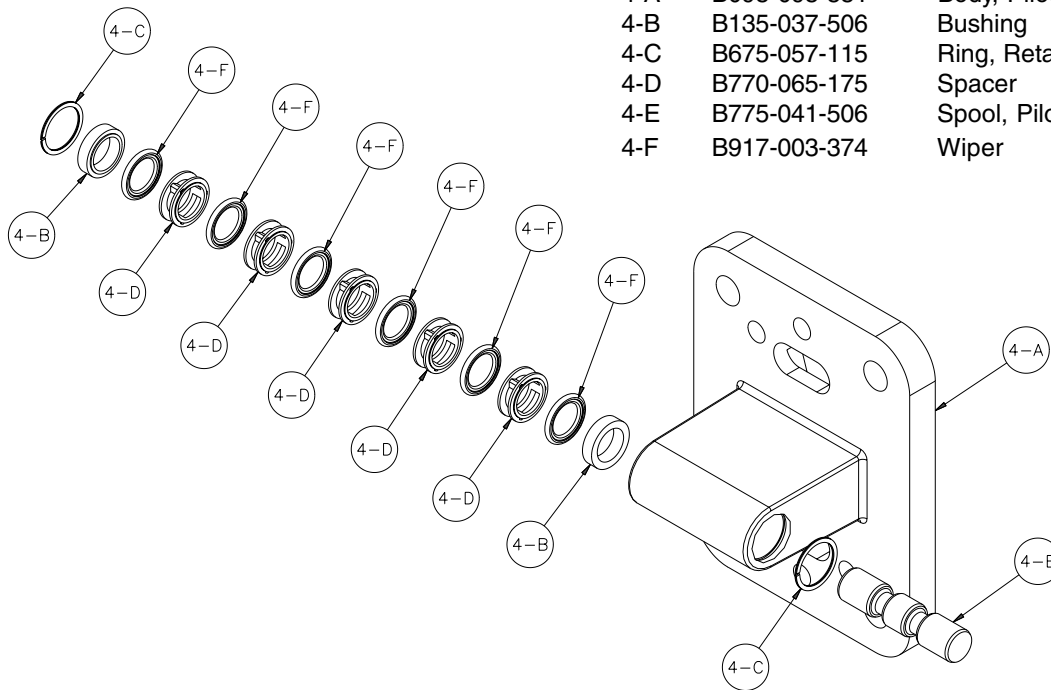

## PILOT VALVE SERVICING

To service the pilot valve first shut off the compressed air supply, bleed the pressure from the pump, and disconnect the air supply line from the pump.

**Step #1:** See PUMP ASSEMBLY DRAWING.

Using a 1/2" wrench or socket, remove the four capscrews (items 11) and four flat washers (items 38). Remove the air inlet cap (item 8) and air inlet gasket (item 20). The pilot valve assembly (item 4) can now be removed for inspection or service.

**Step #2:** Disassembly of the pilot valve.

Remove the pilot valve spool (item 4-E). Wipe clean, and inspect for dirt, scratches or wear. Replace the spool if necessary.

Remove the two retaining rings (items 4-C) from each end of the pilot valve body.

Remove the two pilot valve bushings (items 4-B), five spacers (items 4-D), and six spool wipers (items 4-F) by pushing gently from other end of the pilot valve body. Inspect the wipers for cuts and/or wear. Replace any wipers as necessary.

**Step #3:** Re-assembly of the pilot valve.

First install a retaining ring to one end of the pilot valve. Install one bushing making sure the step side faces toward the wiper. Apply a light coating of grease to the outside diameter of each wiper. Next, gently push in the wipers and spacers until they are against the installed retaining ring and bushing in the opposite end of the pilot valve body. Install the remaining bushing making sure the step side faces the wiper. Install the remaining retaining ring.

Apply a light coating of grease to the inner diameter of each wiper. Also apply a light coating of grease to the outer diameter of the pilot valve spool and gently push the spool through each wiper.

**Step #4:** Inspect the actuator plungers.

See ILLUSTRATION AT RIGHT. The actuator plungers (items 31) can be reached through the pilot valve cavity in the intermediate assembly (item 5).

Remove the plungers (item 30) from the bushings (item 7) in each end of the cavity. Inspect the installed o-ring (items 27) for cuts and/or wear.

Replace the o-rings if necessary. Apply a light coating of grease to each o-ring and re-install the plungers in to the bushings. Push the plungers in as far as they will go.

To remove the bushings (item 7), first remove the retaining rings (item 32) by using a flat screwdriver. NOTE: It is recommended that new retaining rings be installed.

**Step #5:** Re-install the pilot valve assembly into the intermediate assembly.

Be careful to align the ends of the stem between the plungers when inserting the stem of the pilot valve into the cavity of the intermediate.

Re-install the gasket (item 20), air inlet cap (item 8), capscrews and washers (items 11 and 38).

Connect the air supply to the pump. The pump is now ready for operation.



## IMPORTANT!

*Read these instructions completely, before installation and start-up. It is the responsibility of the purchaser to retain this manual for reference. Failure to comply with the recommendations stated in this manual will damage the pump, and void factory warranty.*

## ACTUATOR PLUNGER SERVICING

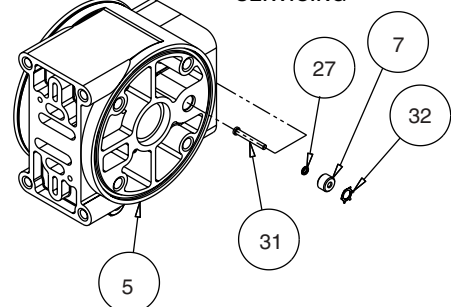

## Diaphragm Service Drawing, with Overlay

## Diaphragm Service Drawing, Non-Overlay

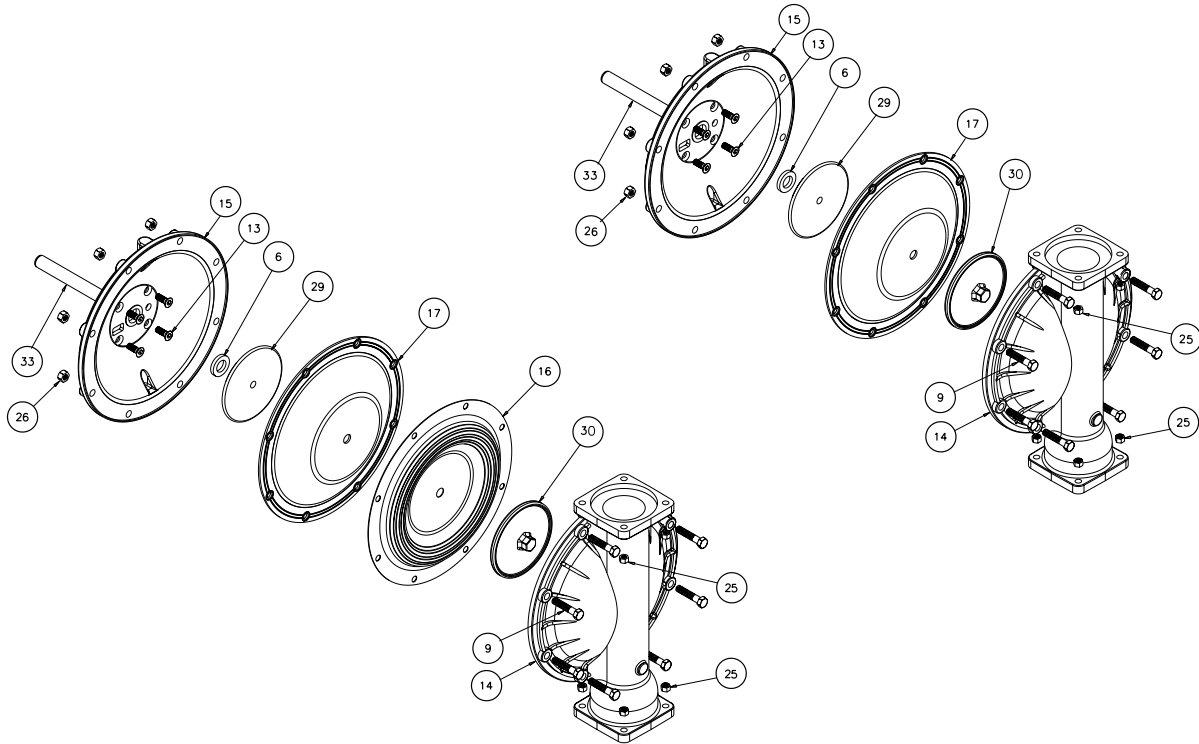

### DIAPHRAGM SERVICING

To service the diaphragms first shut off the suction, then shut off the discharge lines to the pump. Shut off the compressed air supply, bleed the pressure from the pump, and disconnect the air supply line from the pump. Drain any remaining liquid from the pump.

**Step #1:** See the pump assembly drawing, and the diaphragm servicing illustration.

Using a  $11/16$ " and a  $5/8$ " wrench or socket, remove the 16 capscrews (item 10), hex nuts and lockwashers that fasten the manifolds (items 22 & 23) to the outer chambers (items 14).

**Step #2:** Removing the outer chambers.

Using a  $3/4$ " wrench or socket, remove the 16 capscrews (items 9), and hex nuts that fasten the outer chambers, diaphragms, and inner chambers (items 15) together.

**Step #3:** Removing the diaphragm assemblies.

Use a  $11/16$ " (27mm) wrench or six pointed socket to remove the diaphragm assemblies (outer plate, diaphragm, and inner plate) from the diaphragm rod (item 33) by turning

anti-clockwise.

Insert a 1/4-20 capscrew or set screw into the smaller tapped hole in the inner diaphragm plate (item 29). Insert the protruding stud and the 1/4-20 fastener loosely into a vice. Use a  $11/16$ " wrench or socket to remove the outer diaphragm plate (item 30) by turning anti-clockwise. Inspect the diaphragm (item 17) for cuts, punctures, abrasive wear or chemical attack. Replace the diaphragms if necessary.

**Step #4:** Installing the diaphragms.

Push the threaded stud of the outer diaphragm plate through the centre hole of the diaphragm. Thread the inner plate clockwise onto the stud. Insert the loose assembly with the above 1/4-20 fastener back into the vice. Use a torque wrench to tighten the diaphragm assembly together to 50 ft. lbs. (67.79 Newton metres). Allow a minimum of 15 minutes to elapse after torquing, then re-torque the assembly to compensate for stress relaxation in the clamped assembly.

**Step #5:** Installing the diaphragm assemblies to the pump.

Make sure the bumper (item 6)

is installed over the diaphragm rod.

Thread the stud of the one diaphragm assembly clockwise into the tapped hole at the end of the diaphragm rod (item 33) until the inner diaphragm plate is flush to the end of the rod. Insert rod into pump.

Align the bolt holes in the diaphragm with the bolt pattern in the inner chamber (item 15).

Fasten the outer chamber (item 14) to the pump, using the capscrews (items 9), and hex nuts.

On the opposite side of the pump, pull the diaphragm rod out as far as possible. Make sure the bumper (item 6) is installed over the diaphragm rod.

Thread the stud of the remaining diaphragm assembly clockwise into the tapped hole at the end of the diaphragm rod (item 33) as far as possible and still allow for alignment of the bolt holes in the diaphragm with the bolt pattern in the inner chamber (item 15).

Fasten the remaining outer chamber (item 14) to the pump, using the capscrews (items 9), and hex nuts.

**Step #6:** Re-install the manifolds to the pump, using the capscrews (items 10), hex nuts, and lockwashers.

The pump is now ready to be re-installed, connected and returned to operation.

### OVERLAY DIAPHRAGM SERVICING

The overlay diaphragm (item 17) is designed to fit over the exterior of the standard TPE diaphragm (item 16).

The molded directional arrows on the overlay diaphragm must point vertically.

Follow the same procedures described for the standard diaphragm for removal and installation.

**CHECK VALVE SERVICING**

Before servicing the check valve components, first shut off the suction line and then the discharge line to the pump. Next, shut off the compressed air supply, bleed air pressure from the pump, and disconnect the air supply line from the pump. Drain any remaining fluid from the pump. The pump can now be removed for service.

To access the check valve components, remove the manifold (item 23 or item 22 not shown). Use a 5/8" & 11/16" wrench or socket to remove the fasteners. Once the manifold is removed, the check valve components can be seen.

Inspect the check balls (items 2) for wear, abrasion, or cuts on the spherical surface. The check valve seats (item 35) should be inspected for cuts, abrasive wear, or embedded material on the surfaces of both the external and internal chambers. The spherical surface of the check balls must seat flush to the surface of the check valve seats for the pump to operate to peak efficiency. Replace any worn or damaged parts as necessary.

Reassemble the check valve components. The seat should fit into the counter bore of the outer chamber.

The pump can now be reassembled, reconnected and returned to operation.

**METALLIC SEATS**

Two o-rings (or seals) (item 28) are required for metallic seats.

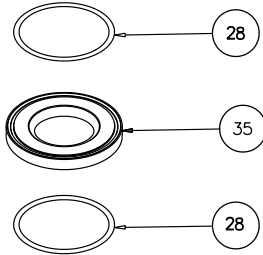

**with Metallic Seats**

**Check Valve Drawing**

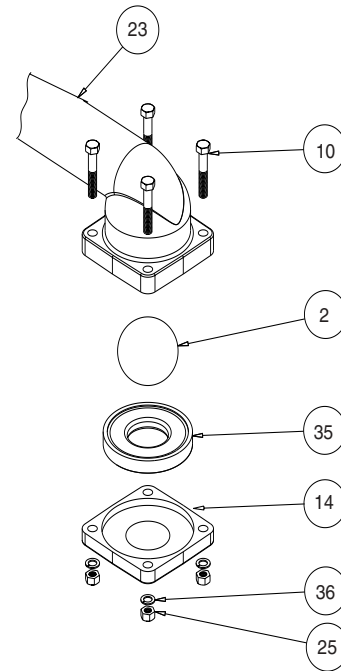

**with Non-Metallic Seats**

**PUMPING HAZARDOUS LIQUIDS**

When a diaphragm fails, the pumped liquid or fumes enter the air end of the pump. Fumes are exhausted into the surrounding environment. When pumping hazardous or toxic materials, the exhaust air must be piped to an appropriate area for safe disposal. See illustration #1 at right.

This pump can be submerged if the pump materials of construction are compatible with the liquid being pumped. The air exhaust must be piped above the liquid level. See illustration #2 at right. Piping used for the air exhaust must not be smaller than 1" (2.54 cm) diameter. Reducing the pipe size will restrict air flow and reduce pump performance. When the pumped product source is at a higher level than the pump (flooded suction condition), pipe the exhaust higher than the product source to prevent siphoning spills. See illustration #3 at right.

**IMPORTANT INSTALLATION**

**NOTE:** The manufacturer recommends installing a flexible hose or connection between the pump and any rigid plumbing. This reduces stresses on the molded plastic threads of the air exhaust port. Failure to do so may result in damage to the air distribution valve body.

Any piping or hose connected to the pump's air exhaust port must be physically supported. Failure to support these connections could also result in damage to the air distribution valve body.

**CONVERTED EXHAUST ILLUSTRATION**

